

Smile Line ☺

made in switzerland

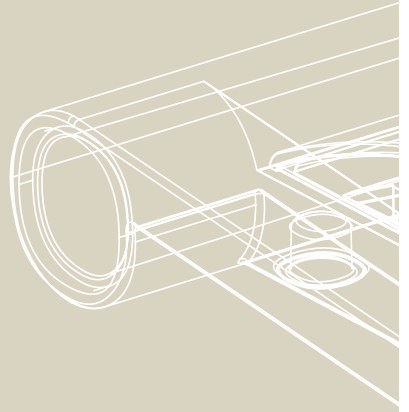

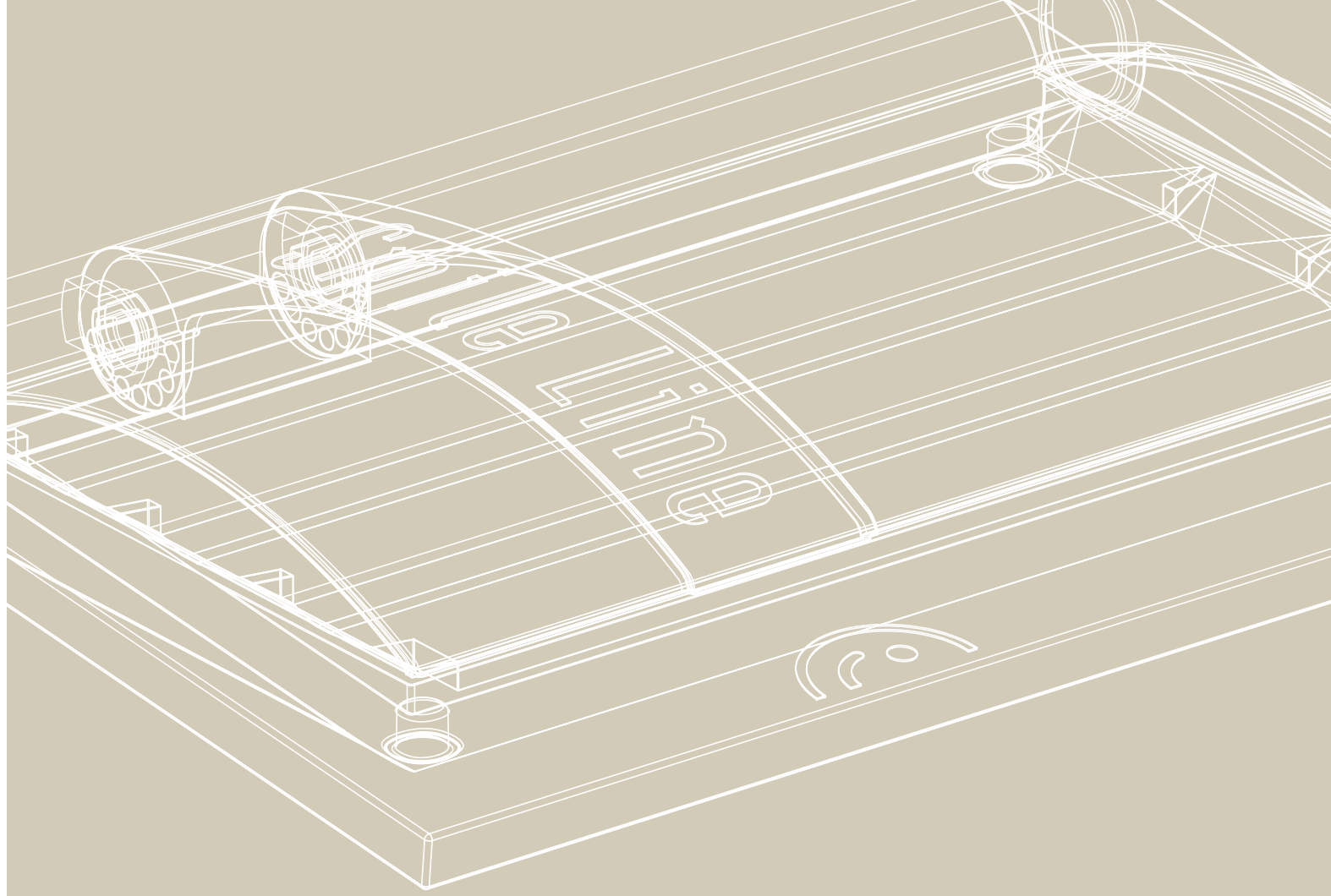



VISION

« Architecture is more a way of thinking than a job »

Le Corbusier – architect, city planner painter born in La Chaux-de-Fonds (Switzerland) in 1887

Le Corbusier was with no doubt correct when speaking about architecture. What would he have said if life had led him in dental technology ? Probably something like « dental technology is a way of thinking, not a job »...

On one side, the number of parameters for succeeding in your work is amazingly high. On another side, the required personal commitment makes it most of the time an utopy to turn off the light at 5 :00pm.

Working style at Smile Line is also very close to the one of an architect. The development of a new product, from the birth of the idea to the finished product is quite complex: it starts with the study of feasibility, goes through free-hand sketches, 3D design, production of prototypes, validation tests, tooling production, controls at every step for finishing with the production and assembly. Most of the time, this is more an intense challenge than a relaxing ride on the beach! For the people involved in the development, weeks don't end on Friday afternoon – actually brains continue working, tirelessly.

All this would not be possible without a major ingredient: passion. An unfailling passion for making a genius idea come to reality. A passion so the object, more than just being functional gives also emotion to its user.

Our ultimate dream: that our products, because of their essential qualities, their ergonomy, their exclusivity, make your everyday work easier and make you realize that you are unique!

Olivier Schaeren
CEO Smile Line





INDEX

	Smile Lite	4-5
SHADE TAKING, PHOTOGRAPHY	Smile Capture	6-7
	N.era Collection	8-9
	N.era bRRRush	10-11
	[Njoy] N.era	12-13
BRUSHES, ACCESSORIES	H ₂ O	14-15
	Instrument by Smile Line	16-21
	Instrument sets	22-25
	Implant drivers	26-27
INSTRUMENTS, TOOLS	Micro-Vibes	28-29
	U-mid Classic, U-mid EVO3	32-33
	Wet'n'Dry EVO3, Wet'n'Dry Classic	34-37
MIXING TRAY FOR PORCELAIN	Tinto	38-39
	My Shade Guide for porcelain	40-41
	Sampler	42
	Flexipalette	43
	Compo Cubo	44-45
	Organ.ez	46-47
	Firing tray	48
	Zir.care	49
	Clever spider	50
	The Cube	51
SMART ACCESSORIES	Golden Section	52-53
	New Architect Anterior	54-55
	New Architect Posterior	56-57
	Pontics	58-59
	High Precision Waxes	60
WAX FORMS, WAXES	Holding Gel	61
PILOT LAB	Jan Kaech, Thun	62

SMILE LITE

SIMPLY STUNNING !

Optimized and standardized communication thanks to Smile Lite – the most performing tool for shade matching and live observation of teeth.

Equipped with « daylight – 5500°K » calibrated LEDs, the device allows for consistent conditions for **understanding tooth shades**. Smile Lite is proven to be a very efficient communication tool, immediately essential for clinical staff surgeon and dental technician.

The polarizing filter Style Lense, that can be mounted or removed easily in a second thanks to magnets, is a leading and revolutionnary component of Smile Lite. It provides a totally new and unique vision of teeth : light reflection is annihilated for an amazing result – tooth structure becomes much more easy to appreciate as well as dentin body, characterization, cracks, and other details.

A huge help : the polarizing filter allows **a better understanding of the chroma and value of the tooth !**

More interesting information also on www.smilelite.ch





4

5



Description	Item no.
Smile Lite, complete set incl. polarizing filter Style Lens, charger and mini-USB cable	6500
Style Lens, polarizing filter	6510

SMILE CAPTURE

DENTAL PHOTOGRAPHY BECOMES A SNAP

Instant image transfer, sharing of information on social networks... today this has become a habit for most of us. With no doubt the major argument for an optimized communication between the dentist and lab.

Smile Capture is a set of accessories that allows you **to couple your Smile Lite and your smartphone** for producing professional and high quality pictures and video every day, with much simplicity and self-education.

Smile Capture allows taking pictures without or with the polarizing filter.

The concept is composed of a calibration box, a set of calibration cards and of adaptors for coupling smartphones and Smile Lite. Very important, **an App (download for free on AppStore or PlayStore)** was developed as a full part of Smile Capture.

The product was initially launched on the market working with the most recent generations of iPhones (4-4S-5-5S-6-6plus). Today, after a new development done with Samsung smartphones, an Android version is now available.

More interesting information also on : www.smilelite.ch



Description	Item no.
Smile Capture, complete set incl. calibration box, set of 4x2 calibration cards, SmartConnect universal adaptor, SmartConnect 4-4S, SmartConnect 5-5S, App for iPhone or Android	6550-N
SmartConnect universal adaptor	6560
SmartConnect adaptor iPhone 4-4S	6551-4
SmartConnect adaptor iPhone 5-5S	6551-5
Calibration cards « A », high-value et low value (2 pcs)	6552-A
Calibration cards « B », high-value et low value (2 pcs)	6552-B
Calibration cards « C », high-value et low value (2 pcs)	6552-C
Calibration cards « D », high-value et low value (2 pcs)	6552-D
Calibration cards Asst., high-value et low value (8 pcs)	6552N-Assi



6
7

Patient: Undefined - Date: 00.00.00 15:01:09 - Picture: Sample



Patient: Undefined - Date: 00.00.0 18:17:39 - Picture: Sample



Patient: Undefined - Date: 00.00.00 18:30:09 - Picture: Sample



N.ERA BRUSHES

NEW GENERATION OF PORCELAIN BRUSHES:
REVOLUTIONARY AND EXCLUSIVE

N.era – represents « nera » (black in Italian – the color of their ferrule) or for « new era ». Smile Line's N.era porcelain brushes are made out of an artificial filament of a new era, exclusive and **never seen yet in the dental industry**. We are talking here of a polyamide type filament which undergoes several special chemical treatments.

Its properties **-spring, water absorption, precision and stability of the point, durability-** make it an outstanding tool: they are equal or superior to the best Kolinsky hair quality.

Our pilot laboratories and users speak highly about N.era and are very enthusiastic about this innovation. N.era brushes are setting a new working comfort and **new possibilities** for the precision during porcelain build up.

N.era collection is proposed as a set of four brushes of different sizes. Of course, you can also order any brush of your preferred size as a single instrument. Finally, replacement tips are compatible with all the handles parts of the line «Instrument by Smile Line».



N.era #8-Macchiato (complete brush) : item no. 4200-8
Spare tips #8 (2 pcs) : item no. 4201-8



N.era #6-Cappuccino (complete brush) : item no. 4200-6
Spare tips #6 (2 pcs) : item no. 4201-6



N.era #4-Moka (complete brush) : item no. 4200-4
Spare tips #4 (2 pcs) : item no. 4201-4



N.era #1-Ristretto (complete brush) : item no. 4200-1
Spare tips #1 (2 pcs) : item no. 4201-1



8
9

Description	Item no.
N.era brush Collection, set: brushes 8-Macchiato, 6-Cappuccino, 4-Moka, 1-Ristretto	4200-Asst
Aluminum handle - Macchiato	4000-AH-MAC
Aluminum handle - Cappuccino	4000-AH-CAP
Aluminum handle - Moka	4000-AH-MOK
Aluminum handle - Ristretto	4000-AH-RIS

N.ERA BRRRUSH

THE VIBRATION THAT MAKES A DIFFERENCE

N.era bRRRush is an idea of Roberto Devolio, MDT in Curitiba, Brasil. While bRRRush is using the revolutionary N.era tips, a unique «vibe zone» has been machined on its handle :

When letting the nail of your forefinger stroke back and forth on the surface, you create **a micro-vibration which propagates up to the very end of your brush tip**. The small portion of porcelain on your brush will almost «detach» while transforming itself into a small drop very easy to apply to your build-up. A short video clip on Smile Line's website shows you how impressive it is.

The advantage of this technique lies in the fact that **much less air is integrated in the porcelain during build-up**, synonymous with less porosities in the porcelain after firing - spectacular especially in the incisal area.

N.era bRRRushes are available as a set of four sizes, n° 8, 6, 4 and 1 and can of course be ordered also as single instruments. Item numbers of the replacement tips are the same as N.era tips introduced on the previous pages. It is also possible to order the handle of bRRRush alone, in case you wish to mount a traditional Kolinsky hair brush tip for example.





10

11

Description	Item no.
N.era bRRRush, set of 4: brushes #8, #6, #4, #1	4200-bRRR-Asst
N.era bRRRush #8, complete brush	4200-bRRR-8
N.era bRRRush #6, complete brush	4200-bRRR-6
N.era bRRRush #4, complete brush	4200-bRRR-4
N.era bRRRush #1, complete brush	4200-bRRR-1
bRRRush aluminum handle	4000-AH-bRRR
Spare tips #8, 2 pcs	4201-8
Spare tips #6, 2 pcs	4201-6
Spare tips #4, 2 pcs	4201-4
Spare tips #1, 2 pcs	4201-1

[NJOY] N.ERA

THE FEATHERLIGHT VERSION OF THE N.ERA BRUSH

On request of some customers, Smile Line has decided to complete the N.era assortment with [Njoy] : **colorful, full of joy and good mood... but also extra-light N.era brushes!**

[Njoy] handle is hollow, injected out of ABS-thermoplastic and overmoulded with a soft-touch silicone for a very nice grip.

YOUR CUSTOMIZED SET :

The concept [Njoy] allows you **to compose your own set of brushes according to your own tastes.** Enough to determine the color you wish to receive for each of the four sizes in the set - see item numbers on the right page. Your Smile Line partner will be glad to compose your personal and customized set!

IMPORTANT :

N.era [Njoy] brushes have no interchangeable tips. Smile Line chose that option mainly in order to diminish the weight of the instrument. Of course, it has a positive impact on its retail price while keeping all the advantages of N.era!





12
13

MOJITO

N.era [Njoy] MOJITO #8 : Item no. 4200-MOJ-8
N.era [Njoy] MOJITO #6 : Item no. 4200-MOJ-6
N.era [Njoy] MOJITO #4 : Item no. 4200-MOJ-4
N.era [Njoy] MOJITO #1 : Item no. 4200-MOJ-1

BLOODY MARY

N.era [Njoy] BLOODY MARY #8 : Item no. 4200-BLO-8
N.era [Njoy] BLOODY MARY #6 : Item no. 4200-BLO-6
N.era [Njoy] BLOODY MARY #4 : Item no. 4200-BLO-4
N.era [Njoy] BLOODY MARY #1 : Item no. 4200-BLO-1

SEX ON THE BEACH

N.era [Njoy] S.O. THE BEACH #8 : Item no. 4200-SOB-8
N.era [Njoy] S.O. THE BEACH #6 : Item no. 4200-SOB-6
N.era [Njoy] S.O. THE BEACH #4 : Item no. 4200-SOB-4
N.era [Njoy] S.O. THE BEACH #1 : Item no. 4200-SOB-1

COSMOPOLITAN

N.era [Njoy] COSMOPOLITAN #8 : Item no. 4200-COS-8
N.era [Njoy] COSMOPOLITAN #6 : Item no. 4200-COS-6
N.era [Njoy] COSMOPOLITAN #4 : Item no. 4200-COS-4
N.era [Njoy] COSMOPOLITAN #1 : Item no. 4200-COS-1

BLUE LAGOON

N.era [Njoy] BLUE LAGOON #8 : Item no. 4200-LAG-8
N.era [Njoy] BLUE LAGOON #6 : Item no. 4200-LAG-6
N.era [Njoy] BLUE LAGOON #4 : Item no. 4200-LAG-4
N.era [Njoy] BLUE LAGOON #1 : Item no. 4200-LAG-1

YELLOW CAB

N.era [Njoy] YELLOW CAB #8 : Item no. 4200-YEC-8
N.era [Njoy] YELLOW CAB #6 : Item no. 4200-YEC-6
N.era [Njoy] YELLOW CAB #4 : Item no. 4200-YEC-4
N.era [Njoy] YELLOW CAB #1 : Item no. 4200-YEC-1

H₂O

HYGIENE, LOGIC, ERGONOMIC



H₂O is the essential accessory which completes your porcelain working station, at the right or at the left of your mixing tray. This universal station allows you **to rinse your brush** in fresh water, **to smoothen it** in order to give it the sharpest possible tip on a viscose sponge and finally **to store it**, vertically dipped in water in an independant container.

All H₂O components are independent, which means that you can change the water of the main container without having to touch the storage container... or vice versa. Thanks to the design of the base and the attachment of the storage container, you can decide the position in an angle of 60°, depending on your preference or of the fact you are left or right handed.



14

15



Description	Item no.
H ₂ O, complete set : black base, round container, stock recipient with lid, viscose sponge (2 pcs)	4400
H ₂ O, round container, 1 pc	4410
H ₂ O, storage container with lid, 1 pc	4420
H ₂ O, viscose sponges, 2 pcs	4430



INSTRUMENT BY SMILE LINE



INSTRUMENT by Smile Line

EXCELLENCE, EXCLUSIVITY AND CUSTOMIZATION

Outstanding, exclusive and custom tailored, **INSTRUMENT by Smile** Line is 100% modular.

MANUFACTURING – Each combination requires more than fifty operations before being carefully controlled and packed. The mechanical parts are manufactured in Switzerland by specialists in watch and machinery making and all tips are of the highest quality and of certified European production.

With **INSTRUMENT by Smile Line**, you build up your own selection of tools according to your needs, your tastes and your sensibility. At every moment, you have the possibility to complete your collection and make it evolve as you wish.

BASE MODULES



4000-As Grooved handle, short



4000-A Grooved handle, standard



4000-AH Grooved single handle, hollow



4100-CAs Carbon fiber handle, short



4100-CA Carbon fiber handle, standard



4100-CAL Carbon fiber handle, long

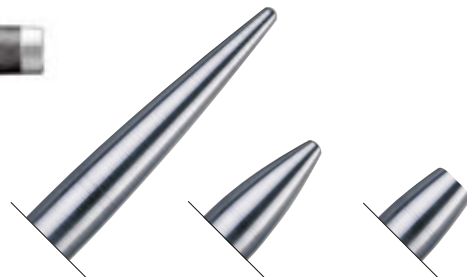

4000-B
Instrument end

4000-BS
Instrument end short

4000-BC
Instrument end cut



How is your style, how is your personality ? More than the –almost- unlimited possibilities of modularity, you have the possibility to select the type of handle that best suits you !

Since 10 years, the collection of **grooved black anodized aluminium handles** has become a classic for thousands of dental technicians.

Are you fascinated by the sensuality and silky touch of wood ? Smile Line offers a whole range of handles carefully made out of **precious wood** : chose among three species and three different shapes.

From this year finally, **carbon fiber** is making a spectacular entry in the family INSTRUMENT by Smile Line : lightness, nobility and emotion of a high-tech material with an irreproachable finish.

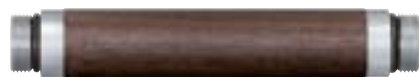

4100-PAs Palissander handle, short



4100-PA Palissander handle, standard



4100-PAL Palissander handle, long, single-end



4100-EBs Ebony of Mozambique handle, short



4100-EB Ebony of Mozambique handle, standard



4100-EBL Ebony of Mozambique handle, long, single-end



4100-VIs Violet wood handle, short



4100-VI Violet wood handle, standard



4100-VIL Violet wood handle, long, single-end

Note : our wood suppliers work exclusively with authorized and certified materials.



- 4100-DPAs Dust brush mounted on palissander short handle
- 4100-DVIs Dust brush mounted on violet wood short handle
- 4100-DEBs Dust brush mounted on ebony of Mozambique short handle
- 4010-DAs Dust brush mounted on black anodized aluminum handle

CERAMIC BRUSHES AND INSTRUMENTS MODULES



4100-XR
Kolinsky brush tip #8-R
Stainless steel connection

4100-XLT
Kolinsky brush tip #8-LT
Stainless steel connection

4000-V6
Module
Kolinsky brush tip #6

4000-LC
Module
Correction brush tip #5

4000-W
Module
Kolinsky brush tip #4

4000-N
Module
Glaze brush #2

4000-O
Module
Stains brush #3/0

4000-P
Module
DUST

4001-V6 (2 pcs)
Brush tips #6

4001-LC (3 pcs)
Brush tips #5

4001-W (3 pcs)
Brush tips #4

4001-N (5 pcs)
Brush tips #2

4001-O (5 pcs)
Brush tips #3/0



4000-OP1
Opaque instrument,
small Al₂O₃ bead

4000-OP2
Opaque instrument,
large Al₂O₃ bead

4000-STE
Depth probe for raw
porcelain
graduated 0.5mm

4000-SG1
Soft-Grip module, single

4000-SG2
Soft-Grip module, double

4000-SG3
Soft-Grip module, mini

4000-Q
Spoon, long

4001-OP1
Refill beads (2 pcs)

4001-OP2
Refill beads (2 pcs)

4010-SG1
Complete instrument
(4000-A + BS + SG1)

4010-SG2
Complete instrument
(4000-A + BS + SG2)

4010-SG3
Complete instrument
(4000-A + BS + SG3)

UNIVERSAL AND WAX INSTRUMENTS MODULES



4000-CM
Universal spatula module

4000-CS
Scalpel module

4000-D
Lecron

4000-E
Zahle, knife

4000-F
Zahle, spatula

4000-G
Spoon short

4000-H
1/2 Hollenback

4001-CM
Spatula blades (3 pcs)

4001-CS
Scalpel blades (10 pcs)

COMPOSITE INSTRUMENTS MODULES



4000-S1
Composite spatula #1

4000-S2
Composite spatula #2

4000-S3
Composite spatula #3

4010-S1
Complete instrument
(4000-AH + S1)

4010-S2
Complete instrument
(4000-AH + S2)

4010-S3
Complete instrument
(4000-AH + S3)



4000-VD
Module
Paste brush

4000-LO
Module
Paste opaque brush, large

4001-LO (5 pcs)
Brush tips

4000-M
Module
Paste opaque brush, small

4001-M (5 pcs)
Brush tips

4000-Sy0
Module
SynTec brush #0

4001-Sy0 (5 pcs)
SynTec brush tips #0

4000-Sy3/0
Module
SynTec brush #3/0

4001-Sy3/0 (5 pcs)
SynTec brush tips #3/0

4000-ZR
Zircon spatula module

4010-ZR
Zircon spatula compl. instrument,
mounted on handle 4000-AH

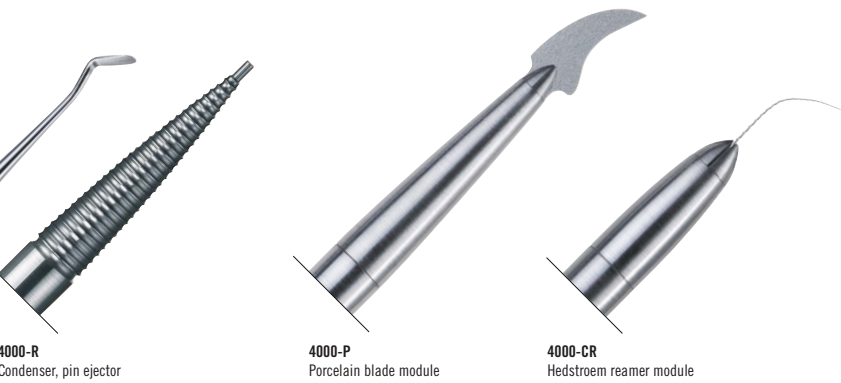

4000-R
Condenser, pin ejector

4000-P
Porcelain blade module

4000-CR
Hedstroem reamer module

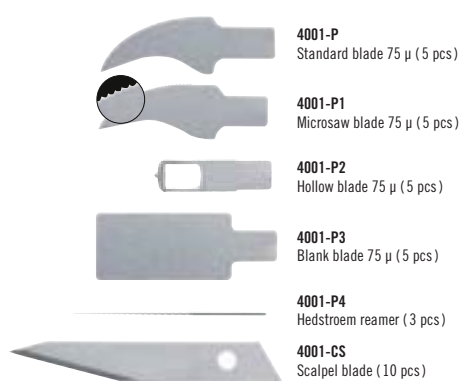

4001-P
Standard blade 75 µ (5 pcs)

4001-P1
Microsaw blade 75 µ (5 pcs)

4001-P2
Hollow blade 75 µ (5 pcs)

4001-P3
Blank blade 75 µ (5 pcs)

4001-P4
Hedstroem reamer (3 pcs)

4001-CS
Scalpel blade (10 pcs)

4001-Z Blades assortment, 1 pc each

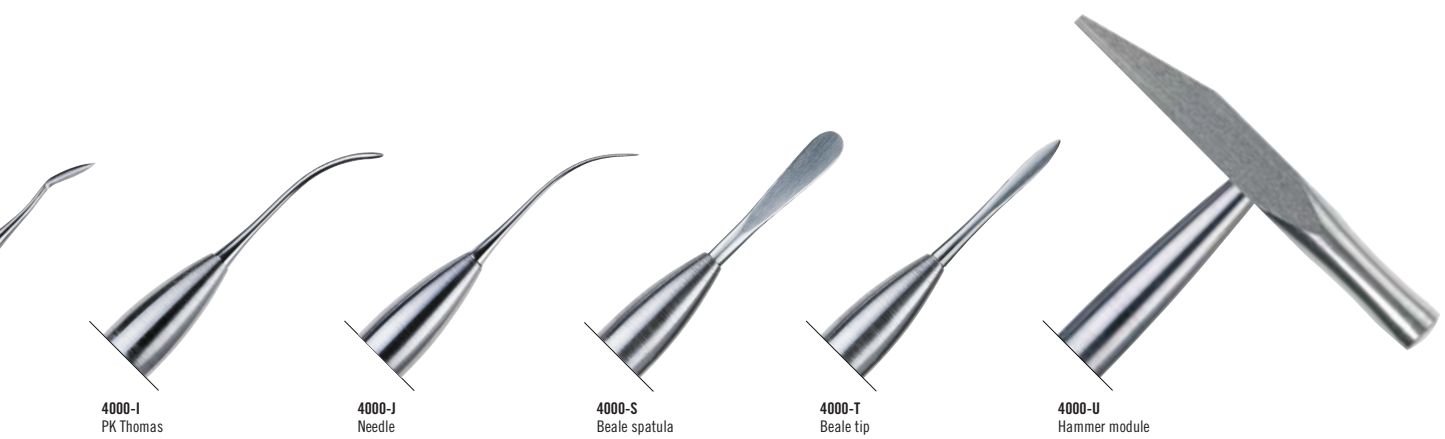

4000-I
PK Thomas

4000-J
Needle

4000-S
Beale spatula

4000-T
Beale tip

4000-U
Hammer module



4000-R1
Rubber #1, Chisel

4010-R1
Complete instrument
(4000-AH + R1)



4000-R2
Rubber #2, Cone

4010-R2
Complete instrument
(4000-AH + R2)



4002 Brushed stainless steel bench stand

20
21

PORCELAIN INSTRUMENT SET

SIMPLY BECAUSE YOU HAVE PASSION FOR WHAT YOU DO

The « porcelain set » is tailored to your needs. Part of the tools are pure Smile Line developments and innovations (ZR spatula – opaque instrument – Soft-Grip – condensing instrument). Some are more traditional like for example the cut-back tools (xx-thin blades – file – spoon). Finally the quality of the Kolinsky brushes is the highest and of best selection. Each Kolinsky brush tip is **severely quality controlled** according to new strict standards implemented with our partner Pinselmeister.

We are convinced that this tool kit will follow you during years of creating dental artistry. You are going to arouse envy around you!

Important information : for those of you who prefer creating their dental artwork with our exclusive **N.era** brushes, the same instrument set exists in a "N.era configuration" instead of Kolinsky. All details and item numbers at the bottom of the page.



Description	Item no.
Porcelain instrument set, highest quality Kolinsky brushes (#8-R and #3/0), total 8 tools for 6 black anodized aluminium grooved handles, assortment of x-thin cut-back blades, micro-fiber tissue	14050-K
Porcelain instrument set, with N.era fiber brushes (#8 and #1), total 8 tools for 6 black anodized aluminium grooved handles, assortment of x-thin cut-back blades, micro-fiber tissue	14050-N
Empty instrument case, mat laminated cardboard, closure with magnets, micro-fiber tissue	14999

WAX INSTRUMENT SET

HIGHEST QUALITY IN TRADITION

Since 20 years, ideas and innovation are part of the DNA of Smile Line. No doubt about this. Having said this, Smile Line never turned down tradition where needed.

Wax instruments deserve –on our opinion– **full respect of dental traditions**. A LeCron or a Zahle spatula will for sure remain classics as long as we'll continue working with wax. It is exactly the philosophy we are following for the tools supplied in the « **wax set** » : all are made in Switzerland or by specialists in Europe. Exclusively.

We wish for you: only a true mix of **very high quality and durability**.



Description	Item no.
Wax instrument set, total 10 tools for 6 black anodized aluminium grooved handles, micro-fiber tissue	14060
Empty instrument case, mat laminated cardboard, closure with magnets, micro-fiber tissue	14999

COMPOSITE INSTRUMENT SET

MODULAR, COMFORTABLE AND INNOVATIVE

As for the entire program INSTRUMENT by Smile Line, the new « **composite set** » is totally modular. It is the only one of the four instrument sets in which you'll find an additional double-ended grooved handle... without instruments attached. We thought that maybe you'll wish to combine one of the flexible spatulas with a rubber tip for creating a double instrument – instead of keeping each of them as a single instrument.



23

24

Description	Item no.
Composite instrument set, total 5 tools for 6 black anodized aluminium grooved handles, micro-fiber tissue	14070
Empty instrument case, mat laminated cardboard, closure with magnets, micro-fiber tissue	14999



I CREATE.... WE CREATE

OBJECT OF DESIRE

I create... we create. These few words have a very simple ambition : to invite you, just for a few moments to stop rushing, to release pressure and to make silence around you for giving them all their dimension : **I create !**

The four sets INSTRUMENT by Smile Line represent the ultimate, **the top in matter of instruments and tools for the dental technician.** They have been thought and conceived to the attention of persons passionate by their work and its creative aspect – for you.

Maybe just one advice : don't forget your personal instrument set on a table – it may disappear at your return !



IMPLANT DRIVERS

IMPLANT DRIVERS FOR LABORATORY

Smile Line reaches a new standard and introduces 8 different drivers compatible with the most popular dental implant systems on the market: Nobel Biocare¹, Straumann¹, Astra Tech¹, 3i¹, Camlog¹, SPI¹, Ankylos¹, Friadent¹. Every driver is available in **two lengths**, standard or extra-long. For an easy and immediate identification, each driver is color coded. In addition, the Station allows you to **centralize all your drivers at the same place in your laboratory**.

Depending on your demands, Implant Drivers are available in separate components so you can build your personal assortment and order the specific drivers you need. The complete set comprising all drivers ready mounted (standard length) plus one solid aluminum Station is another option.

Personalization – modularity. For the creation of your own personal drivers, ends can be ordered alone (i.e. without handle). You have the benefit, if you desire, to mount an individual driver on the precious wooden handles (see page 19). Another available option is the Station constructed of black anodized aluminum.

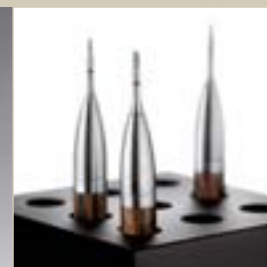

¹ Nobel Biocare, Straumann, Astra Tech, 3i, Camlog, SPI, Ankylos, Friadent are all registered Trade Marks.

Description	Item no.
Implant-Drivers Station, complete set incl. 8 implant drivers (standard length) and one solid aluminum cube, nature anodized	4300
Aluminum cube-station, nature anodized	4301
Aluminum cube-station, black anodized	4302
Dynamometric key	4310

Two solutions are possible for ordering your implant drivers, as shown in the example below: already mounted (4010-L-STR) or composed with separate modules (4000-BC + 4000-As + 4000-FRI).



Smile Line driver Nobel Biocare¹ compatible

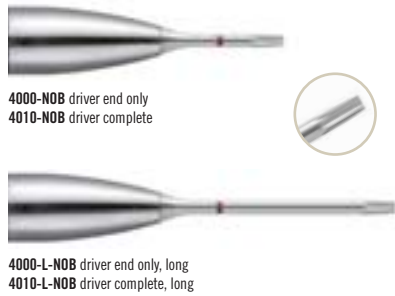

Smile Line driver Straumann¹ compatible

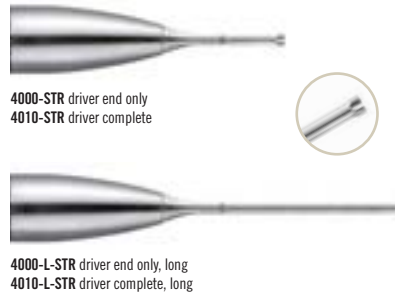

Smile Line driver Astra Tech¹ compatible

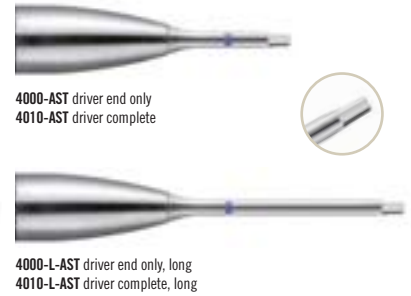

Smile Line driver 3i¹ compatible

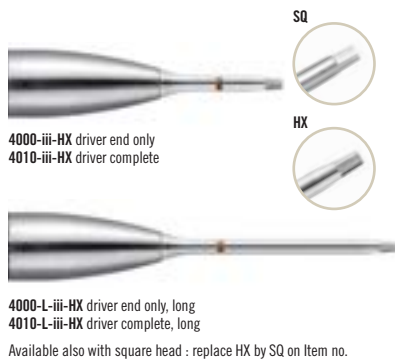

Available also with square head : replace HX by SQ on Item no.

Smile Line driver Camlog¹ compatible

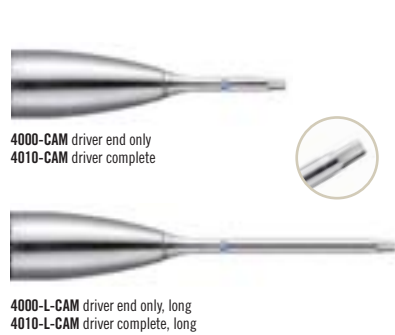

Smile Line driver Ankylos¹ compatible

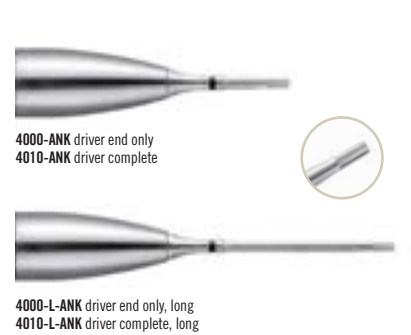

26
27

Smile Line driver Friadent¹ compatible

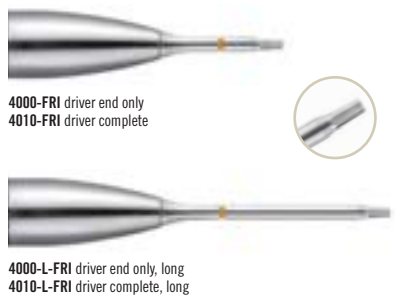

Smile Line driver SPI¹ compatible

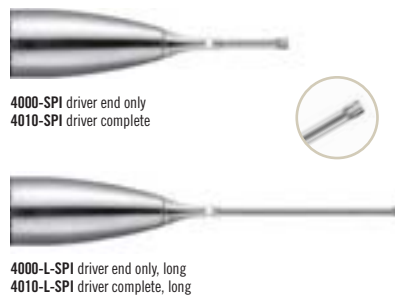

Universal Smile Line driver, 1.4mm
(exists also in 2.5mm)

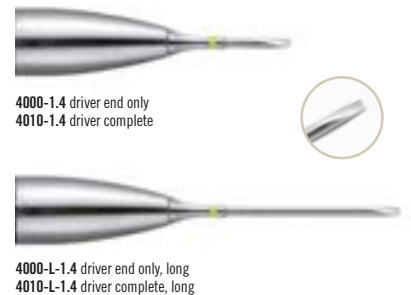

DYNAMOMETRIC KEY

For an optimal precision when tightening the screws of your implant works, Smile Line has developed a dynamometric key which is adaptable to its drivers. The controlled torque is of 9 Ncm. Each key is supplied with one adaptor (4000-BD).
Not compatible with wooden handles.



4310 Dynamometric key



4000-BD Handle adaptor

¹ Nobel Biocare, Straumann, Astra Tech, 3i, Camlog, SPI, Ankylos, Friadent are all registered Trade Marks.

MICRO-VIBES

A REVOLUTION IN YOUR EVERYDAY WORK

Micro-Vibes is a multi-purpose tool of a new and innovative conception. Thanks to a micro-motor equipped with an excentric weight, it provides a **unique micro-vibration** («sonic» effect) which can be directed and controlled. By using Micro-Vibes for mixing, your ceramic's properties will be enhanced and optimized, thanks to the homogenization of its grains before build-up.

More than this, Micro-Vibes allows:

- to extract any micro-bubbles from the mixture
- a regular and thin application of materials such as powder or paste opaques and liners for zirconia
- the activation of materials such as paste opaques and stains in paste
- a local interdental condensation for closing any space after the first ceramic firing
- a help for placing crowns and bridges on the model



Description	Item no.
Micro-Vibes, instrument with universal flexible spatula	01000-MVS
Micro-Vibes, instrument with Al ₂ O ₃ bead for paste-opaques	01000-MVOP
Universal plastic spatulas, spare, 5 pcs	01010-MV
Universal spatulas in natural fiber - horn, 2 pcs	01011-MV
Spare instrument with Al ₂ O ₃ bead for opaques and liners, 1 pc	01020-MV
Spare instrument with double Al ₂ O ₃ bead for opaques and liners, 1 pc	01025-MV
Batteries 1.5V – AAAA, 2 pcs	01030-MV
Assortment of screws, hexagonal wrench, o'rings	01040-MV
Micro-Vibes, micro-motor complete module, 1 pc	01100-MV



#01000-MVS



#01000-MVOP



28

29

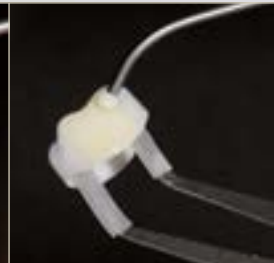

▲ **OPTION 1**
Smile Line proposes a tip with the same design as for the plastic spatula, but realized out of a material owing peculiar properties : horn. This natural fiber offers big flexibility and excellent vibrations transmission at the same time.

▲ **OPTION 2**
You have the possibility to order separately a very special tool provided with two ends equipped with the two different Al_2O_3 beads : the regular 2mm bead and the 1mm diameter bead, very useful for interdental spaces.

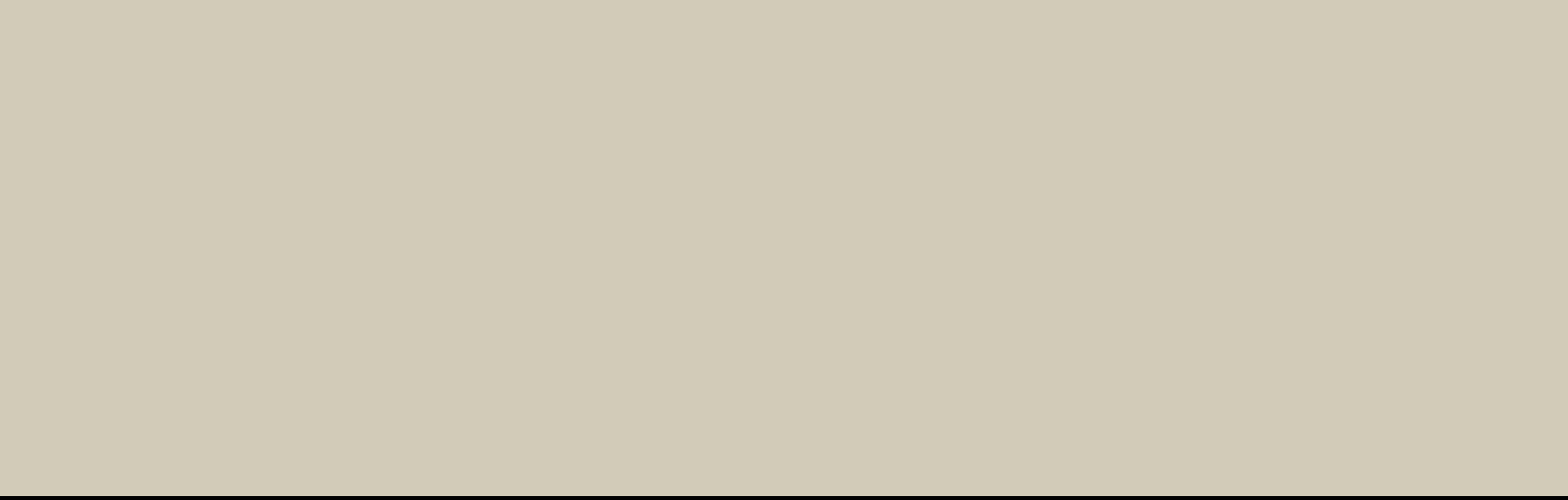

MIXING TRAYS FOR PORCELAINS



U-MID CLASSIC

WET MIXING TRAYS

Since its launch in 1994, U-mid has become worldwide a classic in the segment « wet trays for porcelain ». Its great and undeniable advantages for everyday techniques are:

automatic « wetting » of the powders - permanent consistency - no mixing required - time saving and wonderful working conditions - savings in ceramic powders - ergonomics

Pioneers thanks to hi-tech components

The combination of capillary filters offers great reliability. The ceramic porous plate transports moisture from the reservoir to the surface. At the same time the top-layer microporous membrane-filter works as a humidity regulator and a very smooth working surface. Both components are easy to maintain: the ceramic porous plate can be thoroughly steam cleaned and the microporous membrane-filter can be gently rinsed under running water.

U-mid Classic is available in big format (240x135mm) and in a small format, Light U-mid (150x73mm). As an option, Smile Line offers a black microporous membrane-filter to be put over the traditional white membrane.

U-mid Stains - Smile Line proposes U-mid Stains that works with the same capillarity action but with a different microporous membrane-filter. Of course, the adapted stains liquid allowing an extremely precise positioning of the stains, is included in the kit.



Description	Item no.
U-mid Classic complete set, incl. container/lid unit, ceramic porous plate, 2 white membrane-filters Liquid U-mid Liquid ADVANCED 250ml	1080
U-mid Classic, porous plate (240x135x6 mm), 1 pc	1081
U-mid Classic, white membrane-filters (240x135 mm), 2 pcs	1074
U-mid Classic, black membrane-filters (240x135 mm), 2 pcs	1076
Light U-mid Classic complete set, incl. container/lid unit, ceramic porous plate, 2 white membrane-filters, U-mid Liquid ADVANCED 100ml	1030-N
Light, ceramic porous plate (150x73x6 mm), 1 pc	1031
Light, white membrane-filters (150x73 mm), 2 pcs	1032
Light, black membrane-filters (150x73 mm), 2 pcs	1033

Description	Item no.
U-mid Stains complete set, incl. container/lid unit, ceramic porous plate, 2 white membrane-filters, U-mid Stains Liquid 100ml	1020-N
Stains, ceramic porous plate (150x73x6 mm), 1 pc	1021
Stains, membrane-filters (150x73 mm), 2 pcs	1022
U-mid Stains Liquid, 100ml	1112
U-mid Stains Liquid, 15ml	1113

U-MID EVO 3

BREATHTAKING DESIGN AND ERGONOMICS

For those who desire it, the traditional U-mid capillar filters concept (ceramic porous plate and microporous membrane filter) is also available with the new EVO3 container!!

Breathtaking design with stains drawer integrated (see also p.37).

If technology and dimensions are in all points the same as for U-mid Classic, a new working comfort is now offered to you thanks to a design inspired from the ergonomics of laptops.

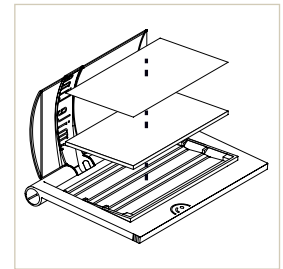

32

33

Description	Item no.
U-mid EVO3, complete set incl. : container/lid with drawer for stains, ceramic porous plate,	
2 white microporous membrane filters, U-mid Liquid ADVANCED 250ml, U-mid Stains Liquid 15ml	2080
U-mid, ceramic porous plate, 240x135x6mm	1081
U-mid, white membrane-filters (240x135 mm), 2 pcs	1074
U-mid, black membrane-filters (240x135 mm), 2 pcs	1076

Description	Item no.
U-mid Liquid ADVANCED, 250ml	1140
U-mid Liquid ADVANCED, 1000ml	1141
U-mid Liquid ADVANCED, 5000ml	1142
U-mid Liquid ADVANCED concentrated, 200ml	1150

WET'N'DRY EVO 3

THE BENEFITS OF THE NANO-TECHNOLOGY

Wet'n'Dry EVO3 is supplied with a glass slab in which six slots have been precisely machined. Cellulose strips are inserted vertically for absorbing the liquid from the reservoir and bring it onto the surface for keeping your porcelain at the desired consistency for several days.

BACKGROUND COLOR – YOUR CHOICE : with the new execution of Wet'n'Dry, you will receive three x-thin (0.3mm) opaque PVC screens that you'll place under the glass slab. Depending on your preference, you can chose between a white... a grey... and a black background for your working surface !



Description	Item no.
Wet'n'Dry EVO3, complete set incl.: container–lid with drawer for stains, glass slab with slots, 3 x-thin PVC screens (white-grey-black), 50 cellulose strips, U-mid ADVANCED Liquid 100ml, U-mid Stains Liquid 15ml, NANO-hydrophobic solution 15ml	12090
Spare glass slab 240x135mm, incl. 3 x-thin PVC screens (white-grey-black), 50 cellulose strips, NANO-hydrophobic solution 15ml	11091
Wet'n'Dry, 50 pcs cellulose strips	11094
Wet'n'Dry, x-thin PVC screens (white-grey-black), 3 pcs	11095
NANO-hydrophobic solution, 15ml	1160

Along with your set Wet'n'Dry EVO3, you will receive a small bottle of a **revolutionary liquid** : « **NANO-hydrophobic solution** ». It is a chemically engineered product with which you can very easily treat the surface of your glass slab. By doing this, you drastically reduce the surface tension of the glass.

The impact on your prepared powders is absolutely amazing : instead of spreading out and compacting with the time, your porcelain masses keep a wonderful cohesion – the working area stays cleaner. **But the most amazing effect** is noticed during porcelain build-up : even if using just distilled water you'll get a fantastic plasticity !

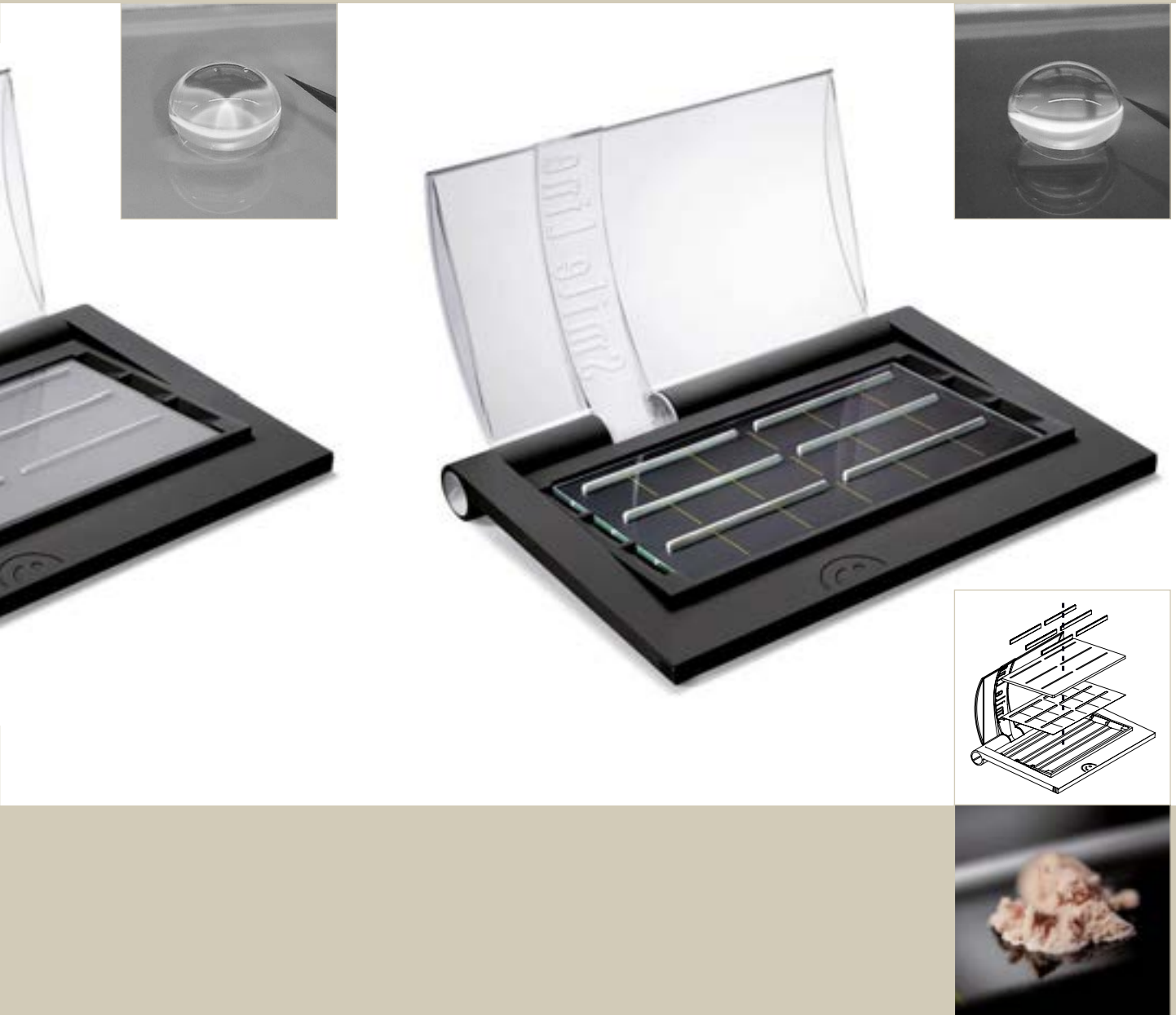

WET'N'DRY 3 CLASSIC

UNBEATABLE RATIO QUALITY-PRICE !

The new nano-technology is also available for the « Classic » container of Smile Line.

Wet'n'Dry 3 Classic shows itself as the mixing tray combining **high technology and price attractiveness**, affordable for all the dental laboratories.

Each set is supplied with a bottle of U-mid Liquid ADVANCED as well as a bottle of NANO-hydrophobic solution.

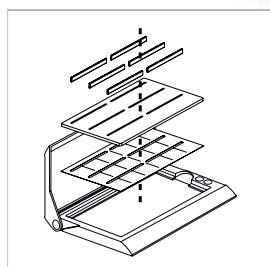
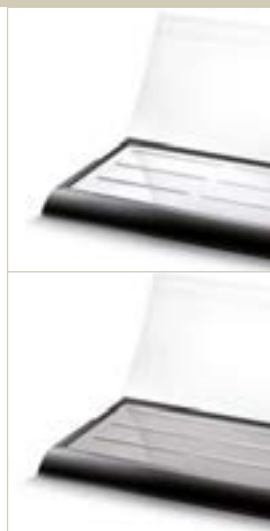

35

36

Description	Item no.
Wet'n'Dry 3 Classic, complete set incl.: container/lid, glass slab with slots, 3 x-thin PVC screens (white-grey-black), 50 cellulose strips, U-mid ADVANCED Liquid 100ml, NANO-hydrophobic solution 15ml	11090
Spare glass slab 240x135mm, incl. 3 x-thin PVC screens (white-grey-black), 50 cellulose strips, NANO-hydrophobic solution 15ml	11091
Wet'n'Dry, 50 pcs cellulose strips	11094
Wet'n'Dry, x-thin PVC screens (white-grey-black), 3 pcs	11095
NANO-hydrophobic solution, 15ml	1160

EVO 3

ULTIMATE DEVELOPMENT !

- **UNIQUE** – Smile Line offers you 2 different technologies – Select the one matching your working style !
- **2 in 1** – each tray is equipped with a drawer for your stains

The base of the EVO3 is completely layered with a black and soft coating for a very nice touch and no light reflection. **Result of a deep study in ergonomics**, the front part is widely inspired from laptops and allows your hand to lay for optimum comfort.

The openings on both sides of the working surface allow an easy refill of the container, no matter if you are right or left handed. The lid, injected out of shock-resistant polycarbonate, can be easily removed from the base.

Sets are supplied with their respective components and include one bottle of each U-mid Liquid ADVANCED, U-mid Stains and NANO-hydrophobic solution (Wet'n'Dry).

EVO3 – are no doubt the most exclusive and advanced wet trays ever seen on the market.

34

37



TINTO

MIXED, STORED, INDEXED

Tinto mixing trays allow you to store pre-mixed products like stains or paste-opaques, protected from dust. Although they are of a traditional concept (dry tray, reinforced polypropylene), Tinto trays profile themselves with their unique **design, ergonomics and compactness** (118x118x25mm). The lid is equipped with a panoramic transparent window made out of polycarbonate and allow you to recognize the contents of the tray at a glance.

Nowadays it is quite common that the same dental laboratory is using **several brands of porcelains**.

Tinto was thought in order to be **stacked one over the other**, saving this way much bench space. It will be childplay to indicate on the side with a marker the reference of the product on the inside.

Two models are available. The first has 9 wells of 18mm diameter and a smaller-deeper well for the liquid. The second model has 15 wells of 14mm diameter as well as two small-deep wells for the liquid.

Tinto is supplied with two pieces, either two identical models, or one of each.





38

39



Description	Item no.
Tinto, set of 2 trays with 9 and 15 wells	1300
Tinto, set of 2 trays with 9 wells	1309
Tinto, set of 2 trays with 15 wells	1315

MY SHADE GUIDE

CREATION OF YOUR PERSONALIZED SHADE GUIDE

Shade guides supplied by the industry are commonly used in today's laboratory. The limits of such shade guides are well known : on one side, the material used for their making is not the one which you have in your bottles (approximate reliability) – this often leads to difficulties of interpretation which could mean a risk for the final result. On the other side, the accuracy of shade taking is not always easy : neither the thickness nor the layering of the industrial samples correspond to the every day reality in a dental laboratory.

With My Shade Guide, the aim of Smile Line is to offer you the possibility to create your own **personalized shade guides based on your daily reality**. As much the samples you'll produce can be basic (one powder), as much there is no limit to the possibilities of layering.



Description	Item no.
My Shade Guide, complete kit: solid aluminum base with PC lid, 5 holders, 25 sticks & clips,	
1 synthetic rubber mould, 1 porcelain separating fluid (8ml), 2 build-up glass slabs, 2 x-thin blades	7500-N
Sticks & clips, 100 pcs	7520-N
Sticks & clips (25 pcs) + holders (5 pcs)	7522-N
Clips, 100 pcs	7525-N
Synthetic rubber moulds, 2 pcs	7530
Build-up glass slabs, 5 pcs	7550
X-thin blades, 2 pcs	7560
Porcelain separating fluid, 2x 8ml	7570
Solid aluminum base with PC lid	7590

PRECISE - ELEGANT - ERGONOMIC - PROFESSIONAL

The concept My Shade Guide provides all components, tools and accessories for the making of your porcelain samples to be used for the realisation of your high-end and unique personalized shade guide.

My Shade Guide is not only a tool for easier and more accurate shade taking, it is also an incredible didactic tool allowing to the apprentice as much as to the expert a better understanding of his assortment of porcelain powders.

REAL SHADES - LAYERING FLEXIBILITY - DIDACTIC - ERGONOMICS - EASY



40
41

▲ The accessories supplied with My Shade Guide allow a very easy making of all your porcelain samples.

- ▲ 1 – Stick
- 2 – Clip
- 3 – Porcelain sample
- 4 – Friction zone
- 5 – Anatomic design
- 6 – Marking surface

SAMPLER

SAMPLER FOR PORCELAIN AND FOR COMPOSITE

This very precise tool allows you to produce porcelain tabs of a determined thickness **from your personal blends** in a very simple and professional way. It is also extremely useful as well for **porcelain firing tests**. It also allows you to produce precise and accurate **tabs out of light curing composite**.

The porcelain portionners allow you to take the exact volume of ceramic powder out of the bottle. They are a need for all precise measurements. Portions taken are of 50, 25, 5 and 1 (mm³) depending on the instrument end chosen.

The black tablets are out of laminated card stock and give you the possibility of gluing and indexing all your tabs for complete customization.



Description	Item no.
Complete kit, incl. sampler, portionners 50-25 and 5-1, indexing tablet	7010
Sampler only	7015
Indexing tablet, 5 pcs	7016
Portionner 50-25	4010-A
Portionner 5-1	4010-B

FLEXIPALETTE

A MUST HAVE FOR INTRA-ORAL PHOTOGRAPHY

In partnership with Styleitaliano, a study group of passionate clinicians and researchers, Smile Line introduces on the market an assortment of very unique and innovative contrastors intended for intra-oral photography: Flexipalette.

Flexipalette is made out of a bendable copper sheet 100% overmoulded with a medical grade silicone rubber, latex free, safe and hypoallergenic.

- Flexipalette can be sterilized in autoclave at 135°C
- Flexipalette is absolutely opaque and reflection-free
- Flexipalette is gentle and soft in the patient's mouth
- Flexipalette can be folded in a 30° to 45° degree angle

When visiting Smile Line's website, you'll discover an instructive video-clip demonstrating you how to use Flexipalette and its great advantages.



42

43



With Flexipalette

Without Flexipalette

Flexipalette A



Flexipalette B



Flexipalette C



Flexipalette
Color Match



Description

Flexipalette, set of 4 forms
Flexipalette, form A
Flexipalette, form B
Flexipalette, form C
Flexipalette, Color Match

Item no.

FP-3100
FP-3001
FP-3002
FP-3003
FP-3004

COMPO CUBO

GREAT COMFORT FOR COMPOSITE HANDLING



Description	Item no.
Compo Cubo complete set	4600
Compo Cubo mixing slab	4600-1
Compo Cubo stains segment - 9 wells	4600-2
Compo Cubo liquid & sponge segment	4600-3
Compo Cubo lid	4600-4
Compo Cubo spare sponges, 3 pcs	4610
Instruments : see page 20-21	

COMPACT, USER-FRIENDLY AND COMFORTABLE

Compo Cubo was created for providing the greatest possible comfort when working with light-curing composites. Out of solid polyurethane (PU), Compo Cubo is composed of 4 independent segments offering full working freedom.

Segment 1: The base -solid and stable- allows to condition/mix the composite – the surface out of PU is non-sticky and is ideal for the composite.

Segment 2: The second segment provides 9 wells intended for the storage of the stains.

Segment 3: The third combines 2 depressions for the liquids and a sponge compartment, very useful for wiping off any excess of liquid on the instrument.

Segment 4: Finally the lid protects the conditioned materials from dust and light.

Compo Cubo is extremely compact (72x72x72mm) and needs just a small space in your drawer. In case you wish to personalize your Compo Cubo, you can order each segment separately.



ORGAN.EZ

SOLID ALUMINUM BURSTAND



Description

Organ.ez, solid aluminum burstand

Item no.

8100

At first sight, some will see a sculpture placed on the bench. Don't be misled: **ORGAN.EZ** is first and foremost extremely useful and ergonomic.

ORGAN.EZ allows you to **systematically arrange** your burs, diamonds, polishers with a simple notion – knowing instantly where to find them instead of having to search.

Made out of **solid aluminum**, ORGAN.EZ is very stable where you place it. For a maximum comfort when taking or replacing the burs, the entrance of each hole starts with a slight angle.

A maximum of 63 instruments with a shaft 2.35 can be placed. On the first level, you'll notice 8 additional holes intended for the placement of your air-turbine burs.

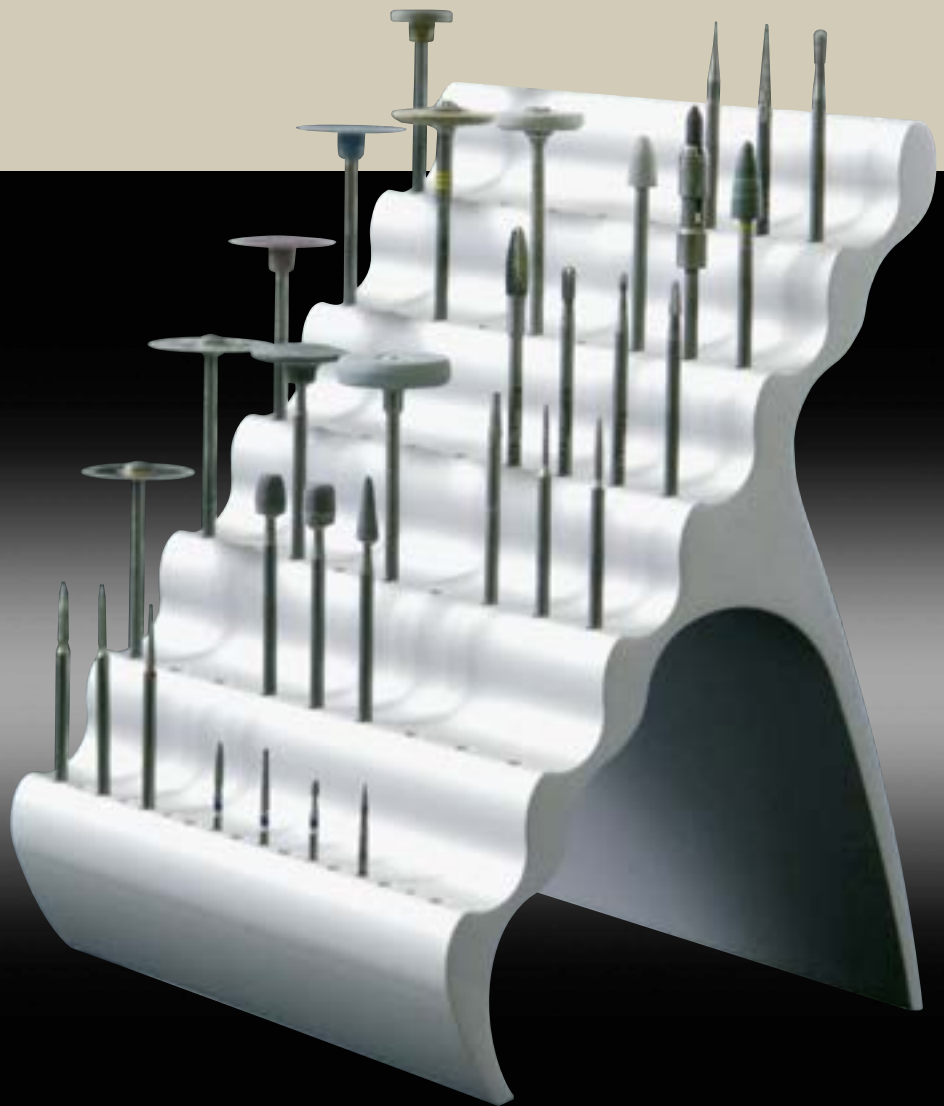

FIRING TRAY

DEVICE FOR CROWNS AND BRIDGES FIRING

This «honeycomb» construction type firing tray offers unlimited choices of placement for the firing of porcelain bridges and crowns.

Two sizes (45 x 45 mm and 55 x 55 mm) are supplied in the starter kit and each is also available separately.

The firing pegs are made from alumina and their cylindrical shape is easy to adjust individually. Three diameters (2, 3 and 5 mm) are supplied to make finding the appropriate peg for each case easy and predictable.



45 x 45 x 12 mm

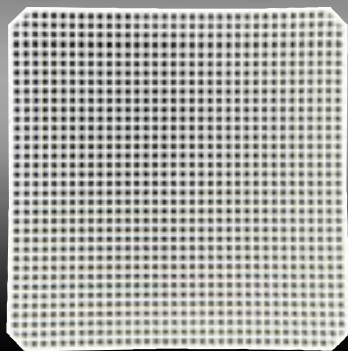

55 x 55 x 12 mm

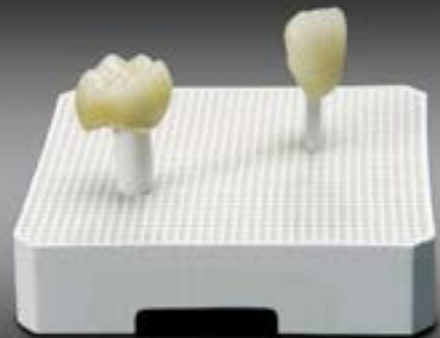
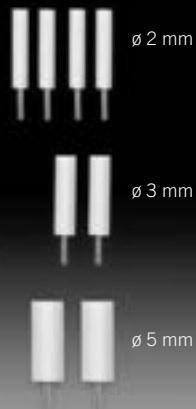

Description	Item no.
Firing tray kit, including: 1 x ea. mullite honeycomb tray 45x45 and 55x55 mm,	
4 alumina firing pegs 2mm, 2 alumina firing pegs 3mm, 2 alumina firing pegs 5mm	9010
Mullite honeycomb tray 45x45mm, 2 pcs	9015
Mullite honeycomb tray 55x55mm, 2 pcs	9016
Alumina firing pegs 2mm, 12 pcs	9020
Alumina firing pegs 3mm, 12 pcs	9021
Alumina firing pegs 5mm, 12 pcs	9022
Alumina firing pegs assortment : 4 pcs each	9029

ZIR.CARE

SINTER DIAMOND FOR ZIRCONIA OXIDE

From the first moment you begin working with Zir.Care, you'll experience new sensations : efficacy, softness and comfort as you have never seen.

Zir.Care is in fact multi-functional : due to the number and shape of the diamond grains, it is engineered for zirconia oxide grinding and its use on layered porcelain is just amazing!

Zir.Care is not manufactured from the traditional channels of diamond disc producers in the dental industry. Instead, it is the object of specific and exclusive development with and for Smile Line.

- fantastic grinding efficacy
- fine grain tool
- durability
- excellent on zirconia oxide as well as on layered porcelain



Wheel 20/4

48

49



Lense 20/2



Wheel 12/2

Description	Item no.
Zir.Care, kit of 3 sinter diamonds for zirconia oxide & 1 cleaning stone	ZC-00-asst
Zir.Care, sinter diamond, wheel 20x4mm	ZC-20W
Zir.Care, sinter diamond, lense, 20x2mm	ZC-20L
Zir.Care, sinter diamond, wheel small, 12x2mm	ZC-12WS
Zir.Care Cleaner, cleaning stone	ZC-cleaner

CLEVER SPIDER

DEVICE FOR PRE- AND POST-SOLDERING

Smile Line's pre- and post-solder spider allows you to work in the easiest and most consistent way possible.

REFRACTORY ALLOY

The Spider is absolutely stable and produced from a refractory alloy which is ideal for its application. Designed in a reinforced arch form, it provides one retentive peg per tooth and all pegs can be bent and unbent for adaptation to the framework. This special technique allows you to work with **less investment material** (time and money savings) and offers the great advantage of **limiting heat absorption**.

ADDITIONAL ACCESSORY USE

Because of its design and conception, the spider is also very much indicated for firing porcelain bridges (PFM or full ceramic).

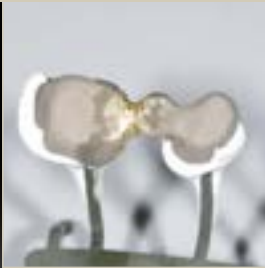

Description	Item no.
Pre- and post-solder spider, twin-set, upper and lower, 2 pcs	9060
Pre- and post-solder spider, upper, 1 pc	9061
Pre- and post-solder spider, lower, 1 pc	9062

THE CUBE

COMPACT ALUMINUM CABINET

This small solid aluminium cabinet is very compact (150 x 150 x 150 mm). Initially, it has been specifically designed for tidying the wax-pontics.

It is obviously also ideal and convenient for placing many other kinds of objects, like for instance attachments, small screwdrivers or other implants accessories. This is the reason why we propose it empty to you, without the wax-pontics.

In its basic execution, it is supplied with 6 drawers, all of them equipped with a tray with 9 compartments. As an option, there are additional drawer configurations available (as per drawing below).

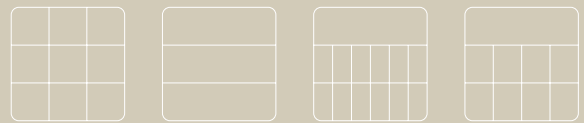

50

51

Description	Item no.
THE CUBE, solid aluminum cabinet anodized natural color (150x150x150mm) with 6 drawers of 9 compartments, empty	2599
The Cube black, same model, anodized black color	2599-B
Drawer tray with 3 compartments, 140x42x19 mm, set of 3 pcs	2591
Drawer tray with 12+1 compartments, 3 pcs	2592
Drawer tray with 8+1 compartments, 3 pcs	2593

GOLDEN SECTION DIVIDER

DIVIDER FOR THE DETERMINATION
OF THE «GOLDEN PROPORTION»

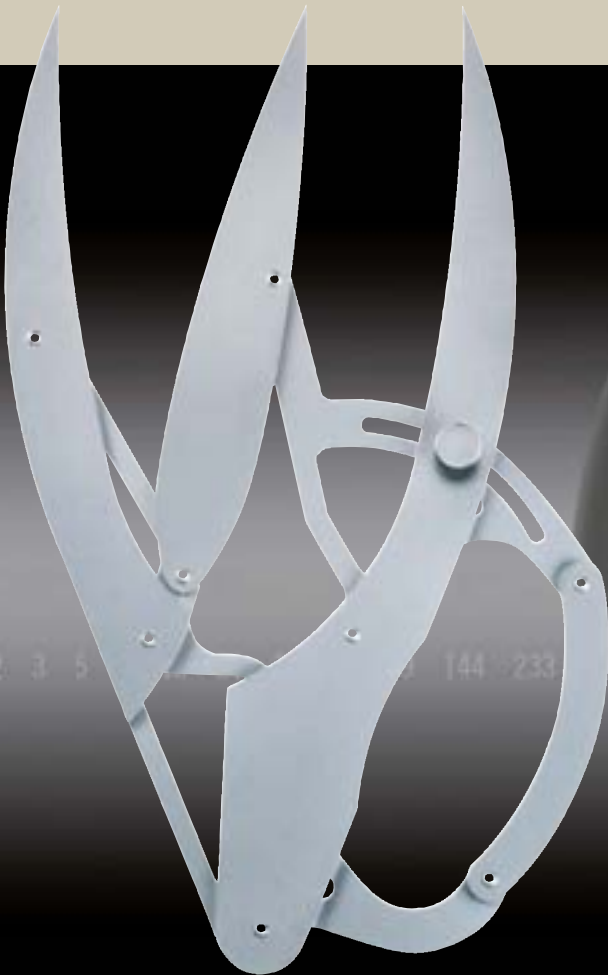
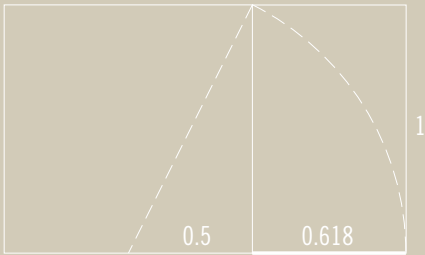

Description	Item no.
Golden Section Divider set, including an assortment of 6 grids blocs, instructions	6010
Grids blocs «golden section», 7.0 mm, 6 pcs	6020-70
Grids blocs «golden section», 7.5 mm, 6 pcs	6020-75
Grids blocs «golden section», 8.0 mm, 6 pcs	6020-80
Grids blocs «golden section», 8.5 mm, 6 pcs	6020-85
Grids blocs «golden section», 9.0 mm, 6 pcs	6020-90
Grids blocs «golden section», 9.5 mm, 6 pcs	6020-95

A CONSTANT WITHIN THE UNIVERSE

The golden proportion is a ratio which result is called mathematically Phi (1.618) or phi (0.618). It is proven that **the universe uses this proportion for its own construction**, from the genetic sequences up to the level of galaxies, passing by construction of flowers, insects, a hand, a face or the whole body.

As we are able to divide a line by its middle or draw a perpendicular, we all recognize the Golden Proportion as a constant for harmony and balance.

A FASCINATING TOOL

Golden Section Divider will **allow you to easily assimilate «physically» the concept**. Slightly or widely open, the Golden Section Divider indicates always two segments respecting the golden proportion. Made out of the highest quality stainless steel and very carefully assembled by hand, the divider is a wonder of precision mechanics. It is supplied together with an assortment of the very useful blocs of grids and of course with instructions of use.

THE GOLDEN PROPORTION IN DENTISTRY

Many studies mention the golden proportion as being one of the ingredients for the harmony of a smile and dentition (see images below). The Golden Section Divider and the grids allow you to discover in a few seconds the theoretical ideal goal in comparison to the real situation in the mouth. These informations are very exciting and very useful for:

- **esthetic anterior cases**
- **dentures**
- **positioning-angle-axis of teeth**
- **gingivectomy**
- **wax-up control**

$$\frac{A}{B} = \frac{B}{C}$$

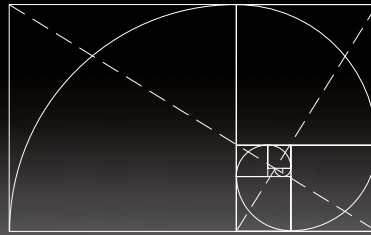
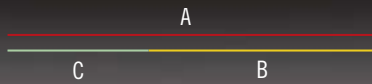

52

53

75025 121393 196418 317811 514229 832040 1346269 2178309 3524578 5702887 9227465 14930352 2415781

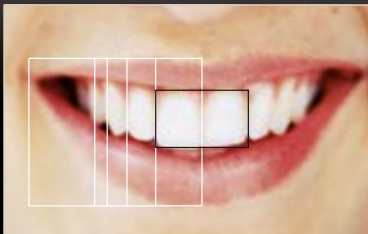

- ▲ In frontal view (visible part of the dentition), anterior teeth are in the golden proportion one to the other. I.e. the width of the central incisor is in proportion to the width of the lateral incisor. The lateral incisor to the canine and the canine to the first premolar.

The segment «central incisor to first premolar» is in the golden proportion to the segment «first premolar to corner of the mouth» (end of smile).

The height of the central incisor is in the golden proportion to the width of the two central incisors (golden rectangle).



- ▲ In the relaxed face, the lip line divides the lower third of the face into two golden proportion segments: «bottom of the nose to lip line» and «lip line to chin».



- ▲ The «Golden Section Grids» printed on paper (assortment of blocs supplied in the kit) are very useful for registrations in the mouth of a patient as well as when working with a model.

N-ARCHITECT WAX-UP ASSISTANT ANTERIOR

PREFABRICATED WAX FACINGS - SILICONE MOULDS

New Architect wax-up assistant ANTERIOR gathers prefabricated white wax facings, out of 100% organic wax. They allow to reach a production efficiency far superior to many other kinds of methods for: **diagnostic wax-ups, implant cases, long terms provisionals, pressable ceramics.**

The kit is composed of beautiful basic shapes: triangular, oval, rectangular as well as a universal lower anterior form, all available in two sizes (L & S). The wax forms are simple and easy to carve. They are also adjustable by heating slightly with a hairdryer.

Smile Line provides with each kit Architect one ADD-ON wax and one POSITION wax samples. ADD-ON wax quality/colour is exactly the same as the wax used for injecting the preforms.

SILICONE MOULDS: in case you prefer using your personal wax, then it is no problem for ordering only the set of silicone moulds : 1 mould per form/size for a total of 8 moulds.



Description	Item no.
New Architect, set of 8 anterior silicone moulds	2111
New Architect wax-up assistant ANTERIOR kit: 48x6 pcs, 8 silicone moulds, 4 PU study models, ADD-ON & POSITION waxes, solid aluminium cube	2110-AA
New Architect, set of 4 anterior PU study models	2112
Refill of 15 pcs of one shape / size	N-Refill
New Architect, ADD-ON white wax, 30g	2150
New Architect, POSITION wax, 30g	2151



54

55

▲ Fast and easy set up of the Architect wax patterns. First apply one drop of «position wax» on the die(s) and set up the wax facing. Position the wax facing(s) and adapt. Finally fill in and finish by using ADD-ON wax.

▲ Architect wax facings and occlusal surfaces are ideal for all cases of implants works.

▲ Long term provisional bridge realized thanks to Architect wax preforms and with the use of a silicone impression key.

N-ARCHITECT WAX-UP ASSISTANT POSTERIOR

WAX OCCLUSAL SURFACES

New Architect wax-up assistant POSTERIOR gathers prefabricated white wax occlusal surfaces. They allow to reach a production efficiency far superior to many other kinds of methods for :

pressable ceramics - any kind of wax-ups - works on implants - long terms provisionals - etc.

The kit is composed of beautiful universal shapes, available in two sizes (L & S). The wax forms are simple and easy to carve. They are also adjustable by heating slightly with a hairdryer. Smile Line provides with each kit one Architect ADD-ON wax and one POSITION wax samples. ADD-ON wax quality / colour is exactly the same as the wax used for injecting the preforms.

The **SILICONE MOULDS** are also available alone as a set of 4 moulds. An essential accessory in every dental laboratory !



Description	Item no.
New Architect, set of 4 posterior silicone moulds	2121
New Architect wax-up assistant POSTERIOR kit : 32x10 pcs, 4 silicone moulds, ADD-ON & POSITION waxes, solid aluminium cube	2120-AP
Refill of 15 pcs of one shape / size	N-Refill
New Architect, ADD-ON white wax, 30g	2150
New Architect, POSITION wax, 30g	2151



56

57

▲ Crown realized with the technique «press to zircon oxide». Obviously, Architect is perfect also for any other press technique (traditional or press-to-metal).

WAX PONTICS

PREFABRICATED ELEMENTS OUT OF WAX

THE CONCEPT

The assortment of Smile Line's prefabricated wax-pontics gathers a program of 54 different shapes/sizes (small-medium-large).

The **optimized design** of each shape allows ease in everyday use.

EASY AND COMFORTABLE

A unique 10 mm long square sprue is integrated to each pattern. This offers you several very big advantages:

- **unequalled positioning comfort**
- **time savings**
- **cooling sprue during casting**
- **support for hanging bridges during porcelain firing**

For starting with this ingenious concept, you have the choice between the acquisition of the complete «CUBE-kit», a very exclusive solid aluminium cabinet containing 324 pcs wax-patterns or the «starter-kit», more economical with 162 pcs.



Description	Item no.
Smile Line Pontics, CUBE full kit, 324 pcs (54 x 6)	2510
Smile Line Pontics, Starter-kit, 162 pcs (54 x 3)	2515
Refill, per shape/size 20 pcs	Refill
Refractory alloy firing peg*, 3 pcs	9050
Hold'on bag, 2 pcs	1500
Mini-Waxtic kit, incl. 750 pcs wax sprues, honeycomb firing tray 45 x 45 mm, refractory alloy firing peg	2520
Mini-Waxtic refill of 750 pcs wax sprues	2525

* 1 firing peg comes along with every kit

SQUARE SPRUE: THE PRINCIPLE

It fits into a special refractory alloy firing peg (supplied with the kits), allowing this way to hang up the bridge during the porcelain firings without any risk of dropping your work.

It is possible to fire bridges – even precious alloy – up to 6-8 units hanging them up with only one sprue without risk of distortion after firing!

MINI WAXTIC

For continuing with the same research of ergonomics as in the wax-pontics, Mini-Waxtic is a small wax sprue (square profile) that you can position on your wax copings. Once casted in alloy, it will be extremely useful and comfortable for holding the object.

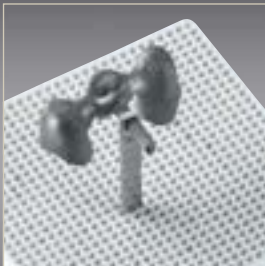

- ▲ The «hold'on bag» allows you to position and stabilize your model into a chosen angle every time your work requires both hands.

HIGH PRECISION WAXES

QUALITY, CONFIDENCE AND WORKING COMFORT

To respond to a big demand, the Smile Line experts-consultants have selected a choice of three essential waxes of a superior quality :

High Precision Margin Wax

This is a red wax with superior characteristics for modelling all marginal areas (copings and inlays). This wax has almost no retraction - inert wax.

High Precision Inlay Wax

Hard modelling wax, light green color, for occlusal surfaces & inlays. It is extremely comfortable to carve. Its qualities allow it to be used also for milling works. The surface obtained after casting or pressing is extremely smooth.

High Precision Modelling Wax

This is a universal, hard wax, deep green color, for modelling (copings, frameworks). It has a very low retraction, burns without leaving any residues and provides a very nice working comfort.

Smile Line's High Precision Waxes are all 100% organic.



Description	Item no.
ADD-ON wax, white, 30g	2150
POSITION wax, 30g	2151
High Precision Margin wax, red, 30g	2160
High Precision Inlay wax, light green, 30g	2161
High Precision Modelling wax, deep green, 30g	2162

HOLDING GEL

GEL FOR TEMPORARILY FIXATION

EASE OF USE

A small drop on the die is enough for holding very well – and temporarily – your delicate porcelain veneers as well as your full-ceramic restorations on the model. This gel is essential for checking the contact points, for the application of correction powders with great ease and for restorations that oppose each other. Transparent, so it doesn't alter the shade – it completely dissolves in water and doesn't leave any residue after firing.



60

61

Description

Holding gel, 2x 6ml

Item no.

5110

PILOT LAB

TRIBUTE AND WARM THANKS

Jan Kaech (ceramist and dental lab owner in Thun – Switzerland) and Olivier Schaeren (CEO at Smile Line) met in Montreux, on the Lake of Geneva, during a dental exhibition at the end of the 80's, a few years before the birth of Smile Line.

Rapidly, this relationship transformed into a nice friendship and developed towards education and organization of porcelain hands-ons.

Since the creation of Smile Line in 1994, Jan has been advising us and helping in many stages with brilliant ideas, for example the validation of the real interest of an invention as well as in all the testing and acceptance phases. His multiple talents, his knowledge and his clairvoyance have always been a great help – for not just saying essential.

So since more than 20 years, Jan and Olivier would meet two-three times a month for exchanging ideas about work and one thousand other topics – meetings normally ending late around a glass of very good red wine, a pizza or a *tagliata di manzo*. Clearly, passion and a solid friendship are the essence of this great relationship.

We wish to share publicly our gratefulness to Jan who has always been on our side, in all the moments of the Smile Line adventure !





Our hope is this catalog allowed you to discover the philosophy and passion of Smile Line.

The products featured on the first pages (Smile Lite & Smile Capture) have a dedicated website - **www.smilelite.ch** - where you'll find more interesting information !

Don't hesitate to contact the Smile Line Partner in your country for your orders and price inquiries. You'll find all information under the section « dealers » on our main website - www.smileline.ch - Finally you have also the possibility to contact us directly per e-mail : mail@smileline.ch. It is a pleasure for us to answer any question in a reactive way.

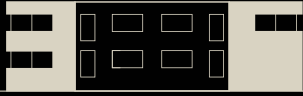

Smile Line – Switzerland

Smile Line SA
Z.I La Clef 5
PO Box 229
CH-2610 St-Imier · Switzerland
T +41 32 944 22 44
F +41 32 944 22 45
mail@smileline.ch
www.smileline.ch

